

Contents

ENGLISH	2
Vehicle Details.....	2
Recommended Compressors.....	3
Parts View	4
Installation Precautions	5
Pre Installation	6
Installation.....	6
Mount Bracket Installation	6
Compressor Installation	7
Idle Pulley Installation.....	7
Drive Belt.....	8
Notes	9

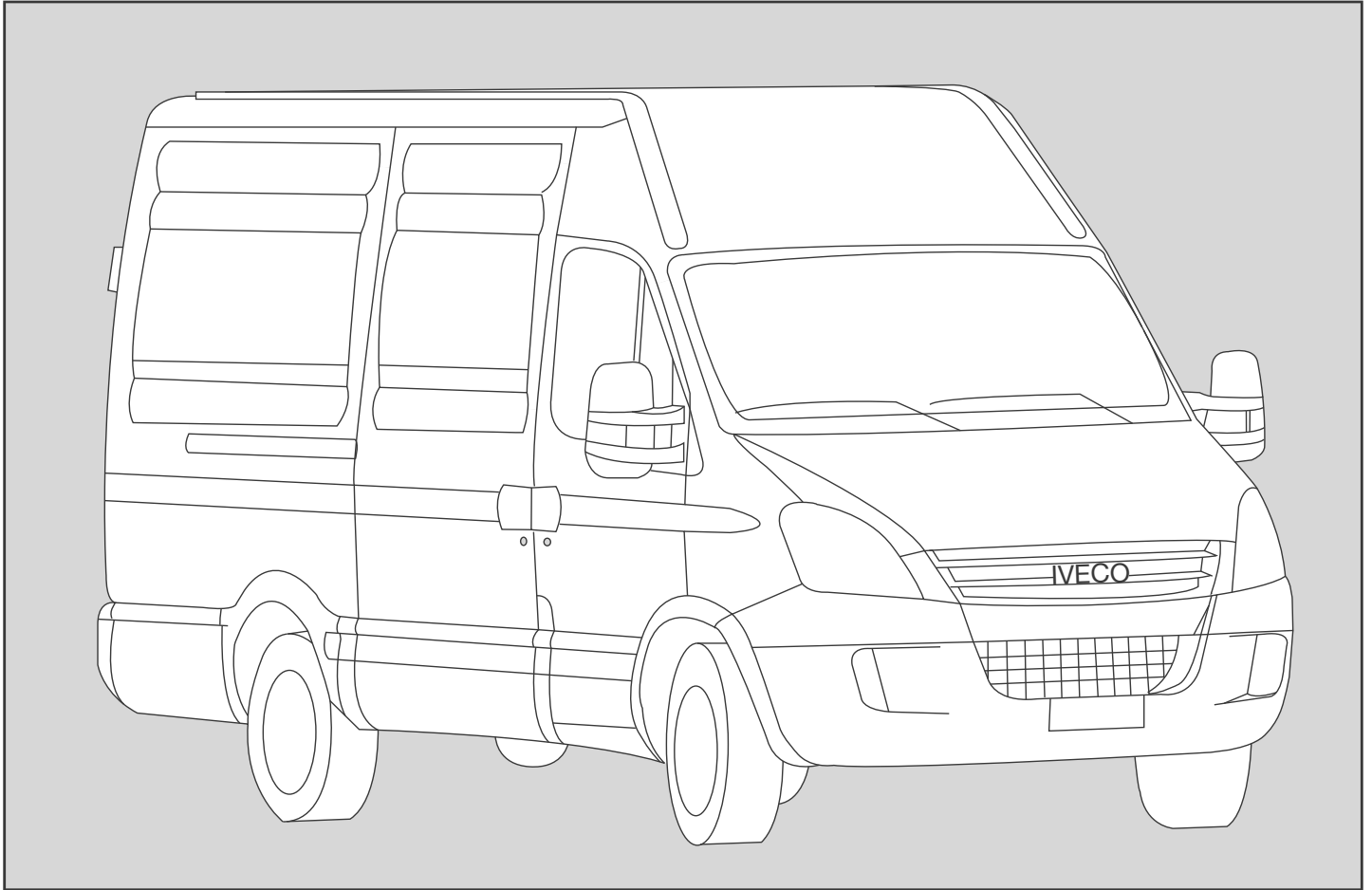

VEHICLE DETAILS

Manufacturer	Iveco
Make	Daily
Model	35S 17, 35C 15/17, 40C 15/17, 50C 15/17, 65C 15/17, 70C 15/17
Engine	Euro 5 / EEV
Engine Details	146HP, 170HP
Year	11.2011>
Chassis Nos.	N/A
LHD	YES
RHD	YES
PAS	YES
A/C	YES/NO
Voltage	12v

KIT DETAILS

Kit Part No.	0500.6742
Description	Standard Kit
Compressor RPM	4823 @ Max engine power output
Fitting Time	120 Minutes
Suction Fitting	90°
Discharge Fitting	90°
Belt Type	6PK 1863
Belt Part No.	0820.6251
Note	Does not fit 205 HP

RECOMMENDED COMPRESSORS

SELTEC	TM-13 HS	TM15-HS	TM16-HS
Comp No	0381.0412	0381.0032	0831.0512
Seltec No.	-	488.45322	488.46322
Mounting	Ear	Ear	Ear
Rotor	8PV	8PV	8PV
Armature	SL	SL	SL
Diameter	123	123	123
Voltage	12	12	12
Orientation	H	H	H
Fitting	3/4 x 7/8	3/4 x 7/8	3/4 x 7/8
Manifold	Bolt	Bolt	Bolt

QUE	QP-13 HS	QP15-HS	QP16-HS
Comp No	0391.0412	0391.0032	0391.0512
QUE No.	-	QP-1624	-
Mounting	Ear	Ear	Ear
Rotor	8PV	8PV	8PV
Armature	SL	SL	SL
Diameter	123	123	123
Voltage	12	12	12
Orientation	H	H	H
Fitting	3/4 x 7/8	3/4 x 7/8	3/4 x 7/8
Manifold	Bolt	Bolt	Bolt

SANDEN	SD5H09	SD5H14	SD7H15
Comp No	-	-	-
Sanden No.	-	-	-
Mounting	-	-	-
Rotor	-	-	-
Armature	-	-	-
Diameter	-	-	-
Voltage	-	-	-
Orientation	-	-	-
Fitting	-	-	-

Notes

COMPRESSOR KIT CONFIGURATIONS

PART NUMBER	COMPRESSOR KIT PART NOS						DESCRIPTION	QTY.
	0513.6742	0515.6742	0516.6742	0516.6742	0516.6742	0516.6742		
0381.0412	●						TM13 Ear Mount 8PV SL 123 12V H 3/4 x 7/8 Bolt	1
0381.0032		●					TM15 Ear Mount 8PV SL 123 12V H 3/4 x 7/8 Bolt	1
0381.0512			●				TM16 Ear Mount 8PV SL 123 12V H 3/4 x 7/8 Bolt	1
0891.0412				●			QP13 Ear Mount 8PV SL 123 12V H 3/4 x 7/8 Bolt	1
0891.0032					●		QP15 Ear Mount 8PV SL 123 12V H 3/4 x 7/8 Bolt	1
0891.0512						●	QP16 Ear Mount 8PV SL 123 12V H 3/4 x 7/8 Bolt	1

● = Additional parts to standard kits.

PARTS VIEW

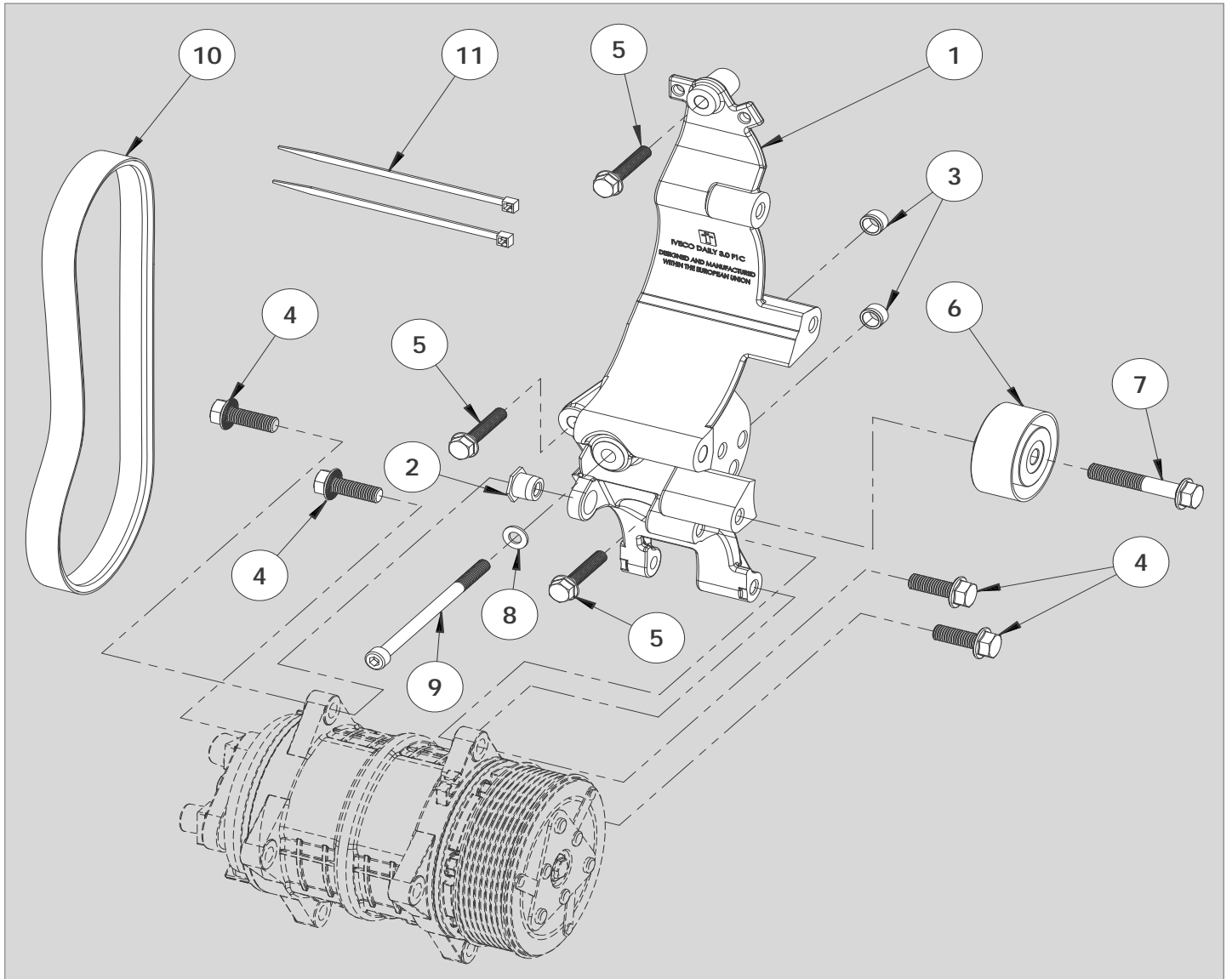

ITEM	PART NO.	DESCRIPTION	QTY.	COMMENTS
1	0440.5203	Compressor Mount Bracket	1	-
2	1710.5073	Compressor Spacer	1	-
3	2800.0291	Dowel Bush	2	-
4	2705.0491	M10 x 30 Hex Flange Lock 1.50	4	-
5	2704.0161	M8 x 45 Hex Flange Lock 1.25	3	-
6	1700.0451	Idle Pulley	1	-
7	2705.0341	Hex flange bolt Durlok - M10 x 50 : 1.50 - 12.9	1	-
8	2808.0011	Washer M8 Flat	1	-
9	2704.5421	Bolt M8 x 130 Hex. Cap Screw 1.25	1	-
10	0820.6251	Belt - Poly Groove 6PK 1863	1	-
11	2763.0021	Cable Tie 370mm x 4.8mm	2	-

FOREWORD

- The purpose of this manual is to facilitate the installation of a direct drive compressor. The information given is merely instructive, should any complications arise contact the Technical department. The manufacturer's warranty does not cover any problems caused by defective installation or alterations made unless authorised. The manufacturer shall not be responsible for any injury, damage or loss caused directly or indirectly as a result of using this manual or the information contained within it.

1 SAFETY MEASURES:

Before fitting the Compressor adapter drive kit, ensure the following for damage:

- Inner and outer trim and body work
- Engine idle pace
- Check all the vehicle functions

Check list:

- Ensure that the right kit has been selected
- Before installing, check that all the correct pieces are present; also ensure that there are no missing or broken pieces
- When fitting, make sure the vehicle is properly protected against damage.

Installation apparatus

- Calibrated torque wrench
- Hand service tools
- Protective covers and shields

2 PRECAUTIONS

- Detach the battery negative lead.
- Torque all bolts where stated using a calibrated torque wrench.
- Take extreme care with moving parts.
- Remove the vehicles ignition key and keep it with you.
- Wear eye safeguards to make sure that liquid refrigerant never touches your skin





Caution: Measures must be followed accurately to steer clear of the possibility of damage to individuals

Warning: This calls awareness to actions which must be pursued to avoid damage to the components.

NB: This calls awareness to make the job easier or gives useful information.

STANDARD FASTENER TORQUE VALUES

- In the absence of specific torque values detailed in this fitting instruction manual, the following chart can be used as a guide to the maximum safe torque for specific size and grade of fastener.

STRENGTH								
	Max Torque		Max Torque		Max Torque		Max Torque	
Dia / Pitch	lb.ft	Nm	lb.ft	Nm	lb.ft	Nm	lb.ft	Nm
M5 x 0.80	2	3	4.5	6	6.5	9	7.5	10
M6 x 1.00	4	5.5	7.5	10	11	15	13	18
M8 x 1.25	10	13	18	25	26	35	33	45
M10 x 1.25	20	27	39	53	57	78	66	90
M10 x 1.50	18	25	37	50	55	73	63	86
M12 x 1.75	33	45	63	85	97	130	111	150
M14 x 2.00	55	75	103	140	151	205	177	240
M16 x 2.00	85	115	159	215	232	315	273	370

PRE-INSTALLATION

Note: Before proceeding please read the Installation Precautions. The letters on drawings relate to text, numbers circled relate to the parts list in this manual.

Dismantle the following:

1. Disconnect the battery
2. Remove the engine under panel
3. If the vehicle is fitted with A/C remove the stretch drive belt.
4. Using a suitable tool rotate the automatic belt tensioner pulley **A** clockwise and insert a suitable 4mm pin, an Allen key is ideal for this purpose at position **B** - Fig.1
5. Remove and discard the original alternator drive belt.
6. Disconnect the wiring loom from the rear of the alternator.
7. Remove the alternator **D**, retain all the alternator securing fixings **E** - Fig 1
8. Remove alternator mount bracket **F** from the engine block - Fig 1
9. Remove the automatic belt tensioner **C** from the alternator mount bracket **F** - Fig 1
10. Retain the automatic belt tensioner **F** and securing bolt - Fig 1
11. Discard the alternator mount bracket **F**
12. Remove the bolt **H** and wiring clip **G** from the engine block, if applicable - Fig 2

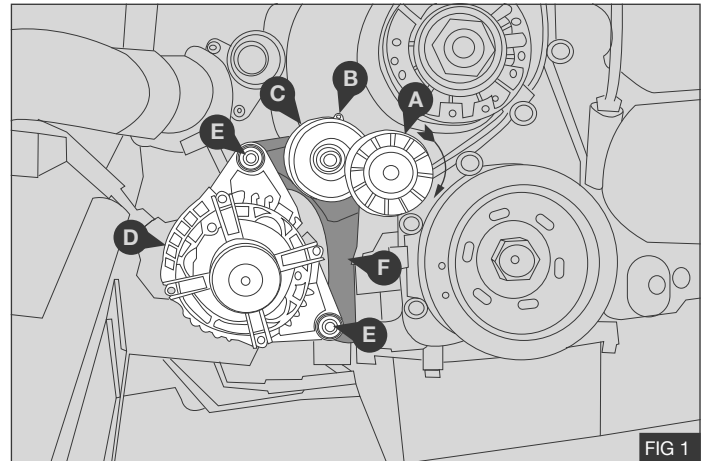

FIG 1

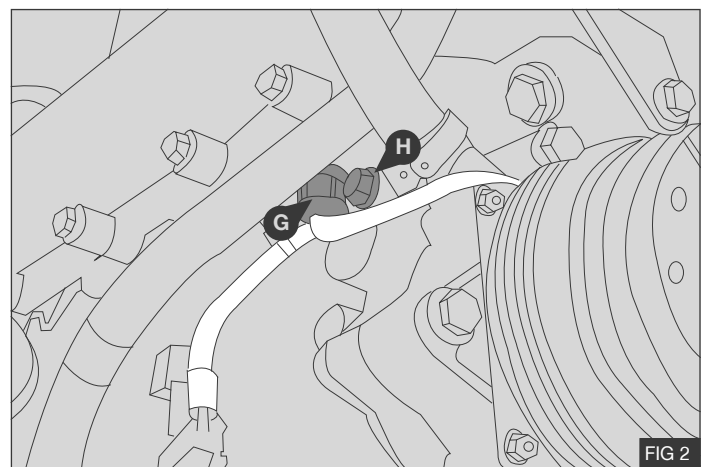

FIG 2

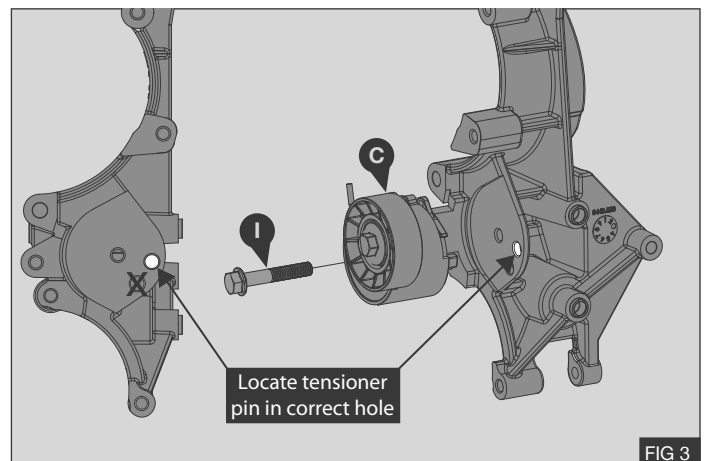

FIG 3

MOUNT BRACKET INSTALLATION

Caution: Make sure the tensioner is located in the correct position as shown in - Fig 3

1. Fit the original automatic tensioner **C** using original bolt **I** - Fig 3
2. Torque bolt **I** to 45Nm / 33 Lb ft - Fig 3
3. Secure the compressor mount bracket assembly **1** to the engine using bolts **5** and **9** with flat washer **8** - Fig 4
4. Torque bolts **5** and **9** to 29 Nm / 21 Lb ft - Fig 4

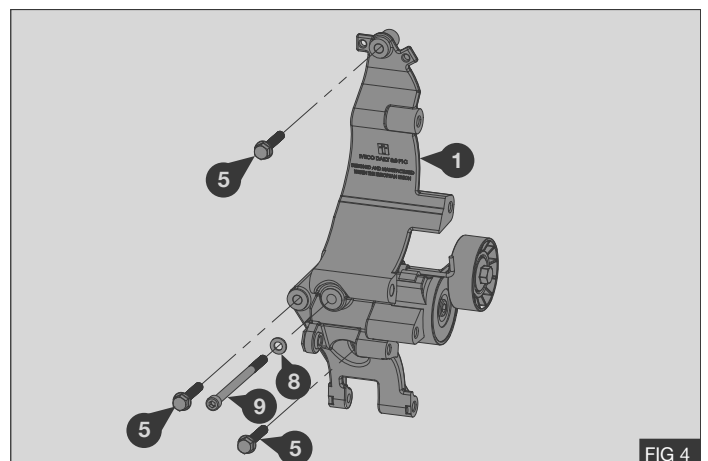

FIG 4

5. Mount the original wiring clip (J) onto the compressor mount bracket (1) if applicable - Fig 5

Caution: Do not use “Loctite” on any bolt unless stated - This will void the Compressor Mount Bracket Warranty.

6. Secure the alternator (K) to the compressor mount bracket (1) using the original bolts (M) and (N) with washer (L) and nut (O) - Fig 6
7. Torque bolts (M) and (N) to 48 Nm / 35 Lb ft

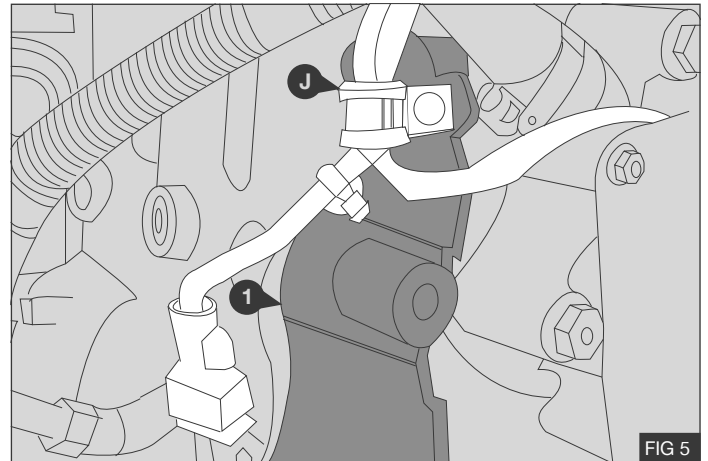

FIG 5

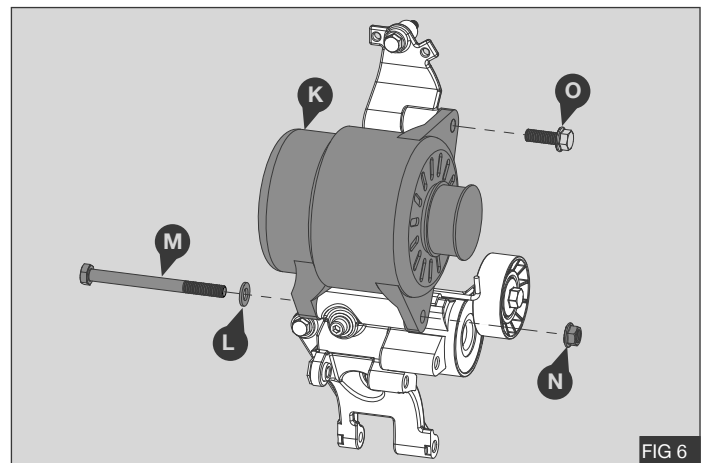

FIG 6

COMPRESSOR INSTALLATION

1. Secure the compressor to the compressor mount bracket (1) using bolts (4) - Fig 7
2. Torque bolts (4) to 58 Nm / 43 Lb ft

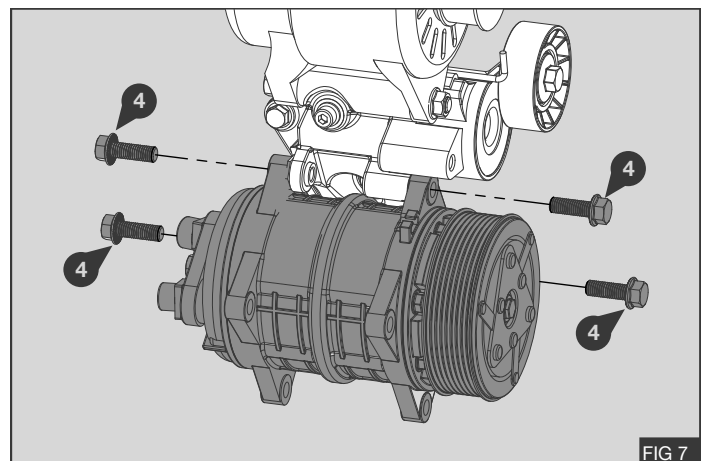

FIG 7

IDLE PULLEY INSTALLATION

1. Secure the idle pulley (4) to the bracket (1) using bolt (7) - Fig 8
2. Torque bolt (7) to 58 Nm / 43lbft.

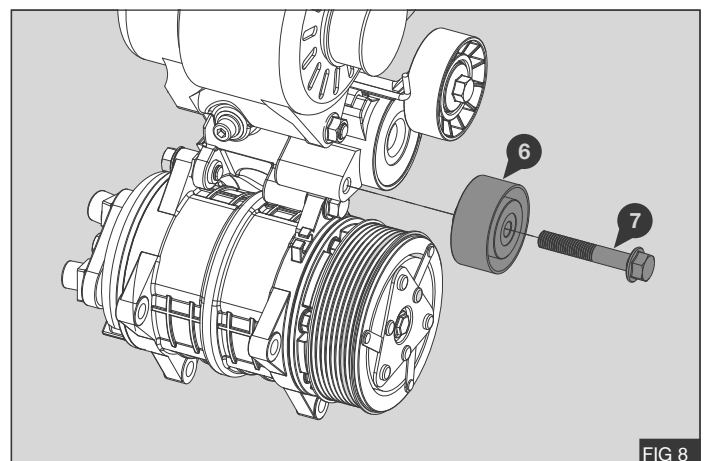

FIG 8

DRIVE BELT

1. Install the supplied drive belt (10) as shown opposite - Fig 9

- A. Crankshaft Pulley
- B. Fan Pulley
- C. Alternator
- D. Idle Pulley
- E. Compressor
- F. Automatic Tensioner

2. If the vehicle is fitted with A/C refit the original stretch drive belt.

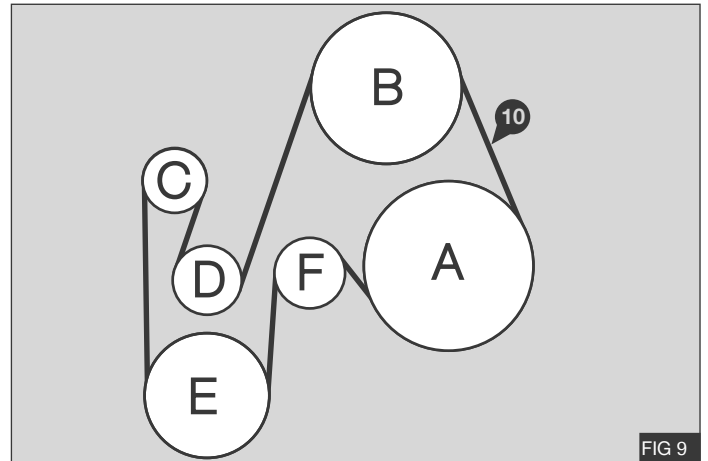

FIG 9

Note: Make sure that the drive belt is fitted into the correct groove of the compressor clutch as shown - Fig.10

Seltec PV8 has the same gauge line as the Sanden PV6 & PV7, belt is fitted to front groove.

Sanden PV8 has a unique gauge line, belt is fitted to second groove.

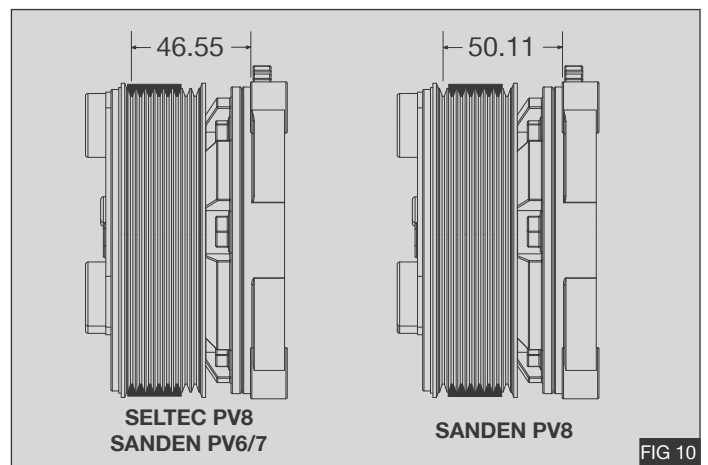

FIG 10

1. Secure the alternator wiring loom (P) to the steel pipe (Q) using supplied cable tie (11) - Fig 11

FINISH

Run the engine with the compressor clutch engaged for five minutes, Check all components and belt tension. Install the supplied belt label in the engine bay

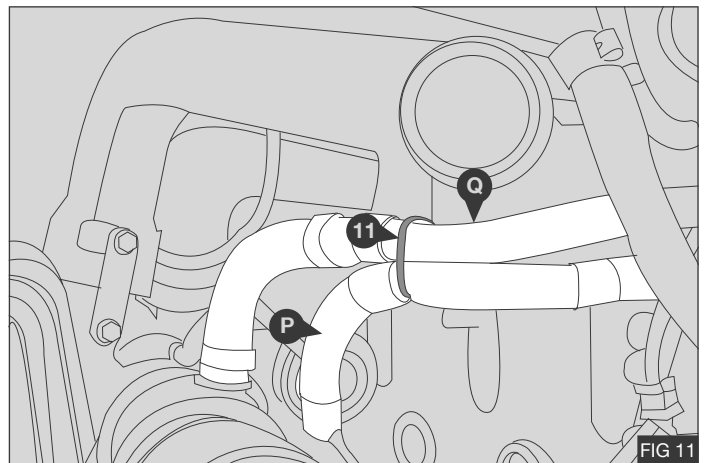

FIG 11